



Selective Pallet Racking

A universal system for direct access to each pallet



General features

Mecalux's conventional pallet racking is the ideal solution for warehouses with a wide range of SKUs that need to be stored on pallets.

Key advantages

- **Goods are easily retrieved** as each pallet can be accessed without shifting other pallets.
- **Total stock control** since each storage location holds a single pallet.
- **Maximum adaptability** to any load type in both weight and volume.

A selective pallet racking layout generally features single-access racking units on either end and double-access (back-to-back) racks in the centre. The type of forklifts or handling equipment used and the height of the storage system determine the width of the working aisles and the height of the racks.

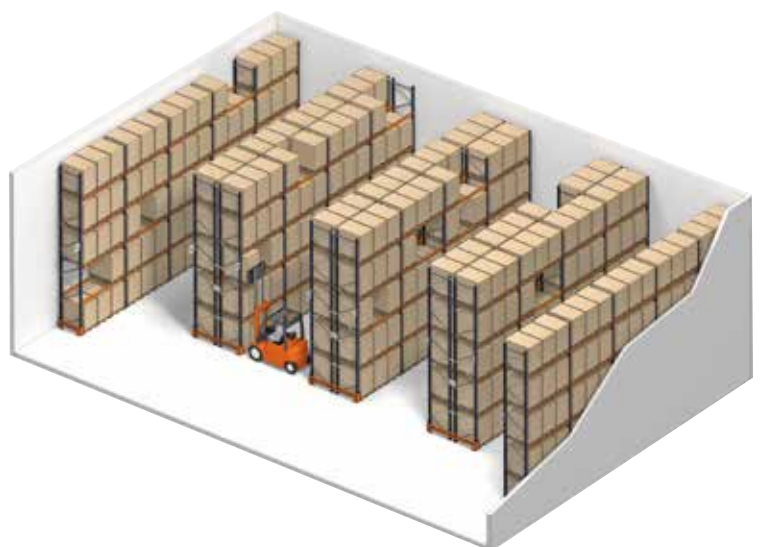



Double-deep pallet racking

Double-deep racks can be installed to increase storage capacity (depending on pallet weight and pallets per SKU). This setup enables one pallet to be stored behind another on each side of the aisle.

Direct access is only available to the first pallet; therefore, this solution is recommended for storing products with multiple pallets per SKU.

This system requires suitable lifting equipment fitted with double-depth telescopic forks.



The most common **pallet racking system**, comprising single-access racks fitted to the walls and double-access (back-to-back) racks in the middle

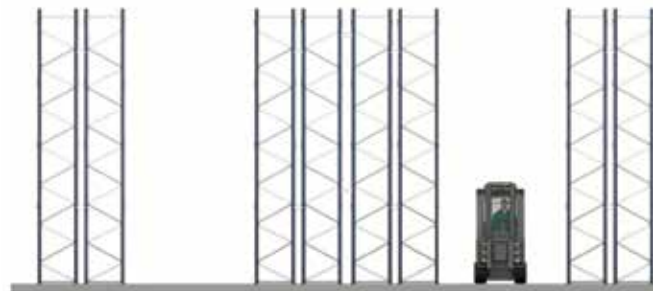

Double-deep conventional system

Measurements and clearances

Aisle

The forklift type and model will determine the minimum clear aisle width between loads. This information can be found in the technical specifications of each forklift.

As a guideline, for 1,200 × 800 mm pallets handled from the 800 mm side, the following are typically used:

Minimum clearances

Pallet stacker:	2,200 to 2,300 mm
Counterbalanced forklift:	3,200 to 3,500 mm
Reach truck:	2,600 to 2,900 mm
Bilateral turret truck:	1,500 to 1,600 mm
Trilateral turret truck:	1,700 to 1,900 mm
Automatic trilateral stacker crane:	1,700 to 1,900 mm
Stacker crane:	1,500 to 1,650 mm

Lifting height and clearance

The clearance height between load levels is calculated by adding the total height of the pallet and its load to the required clearance. This value should never be less than the figures listed in the clearance table on page 12.

Lifting heights also differ for each type of forklift. This information can be found in the technical specifications of each forklift.

Maximum height

Pallet stacker:	5,200 mm
Counterbalanced forklift:	7,000 mm
Reach truck:	12,000 mm
Bilateral turret truck:	13,500 mm
Trilateral turret truck:	14,500 mm
Automatic trilateral stacker crane:	14,500 mm
Stacker crane:	45,000 mm





Most commonly used material handling equipment:



Pallet stacker



Counterbalanced forklift



Reach truck



Bilateral turret truck



Trilateral turret truck

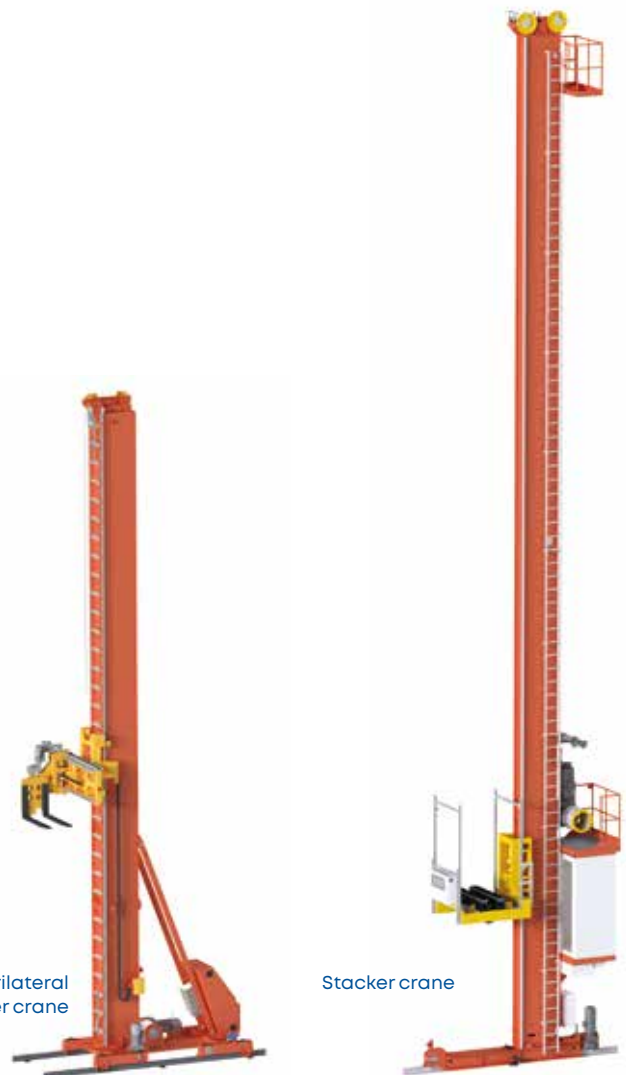

Automatic trilateral stacker crane

Stacker crane



The image above shows a selective pallet racking system with pallets handled from their 1,200 mm side

Unit loads: pallets and containers

Depending on their characteristics, products are stored on pallets or in containers.

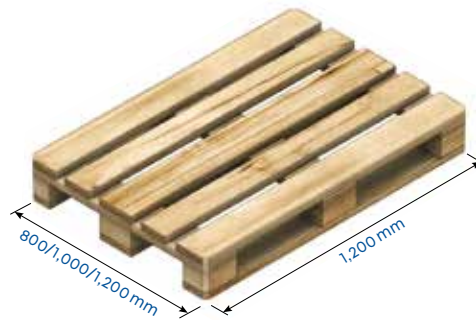

Euro pallets

These pallets measure 800 × 1,200 mm and are handled from the narrower side. Using the same construction standard, pallets are also made in 1,000 × 1,200 mm and 1,200 × 1,200 mm sizes.

They are built with nine blocks and three bottom deckboards for support.

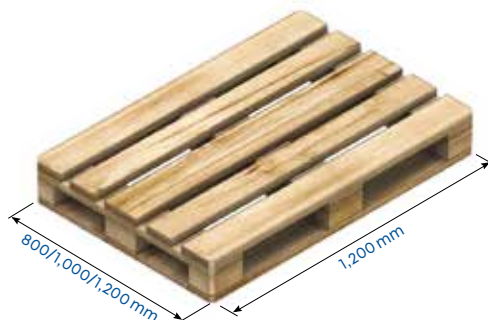

Perimeter base pallets

Built similarly to Euro pallets, these pallets have two additional bottom deckboards, which are connected to the other three.



Selective pallet racking system with pallets handled from their 800 mm side



Selective pallet racking system with metal containers



Containers

Storage containers are usually made of metal. They come in different shapes, sometimes requiring additional components for storage in pallet racking.

Other pallets and containers

In addition to the previously mentioned types, other pallets and containers are also available on the market. They require a specific analysis to determine the most suitable way to store them.

Euro pallets (800 × 1,200 mm) are normally handled from the narrower side, since their three bottom deckboards along the 1,200 mm length rest perpendicularly on the pallet rack beams.

Sometimes, especially to streamline picking operations, they are handled from their wider side (1,200 mm). In such cases, the racking requires components to ensure the pallets are properly supported (pallet support bars).

Components

With its long experience as a racking manufacturer, Mecalux has developed an extensive range of pallet rack profiles and accessories to address the most demanding storage needs.

Components

1. Frame (page 10)
2. Beam (page 16)
3. Safety locking mechanism (page 18)
4. Row spacer (page 18)
5. Anchor bolts (page 11)
6. Levelling shim (page 11)
7. Upright protector (page 25)
8. Upright reinforcer (page 25)
9. Corner protector (page 25)
10. Lateral frame protector (page 24)
11. Cross bracing set (page 32)
12. Top portal tie (page 40)
13. Pallet support bar (page 26)
14. Container support bar (page 27)
15. Chipboard deck support (page 22)
16. Chipboard/melamine-faced chipboard shelves (page 22)
17. Galvanised picking shelves (page 20)
18. Mesh shelf (page 21)
19. Drum supports (page 28)
20. Pallet stop rails (page 30)
21. Fall-protection mesh (page 31)
22. Raised pallet support bar (page 26)
23. Aisle sign (page 33)
24. Safe load warning sign (page 33)
25. P&D stations (page 38)

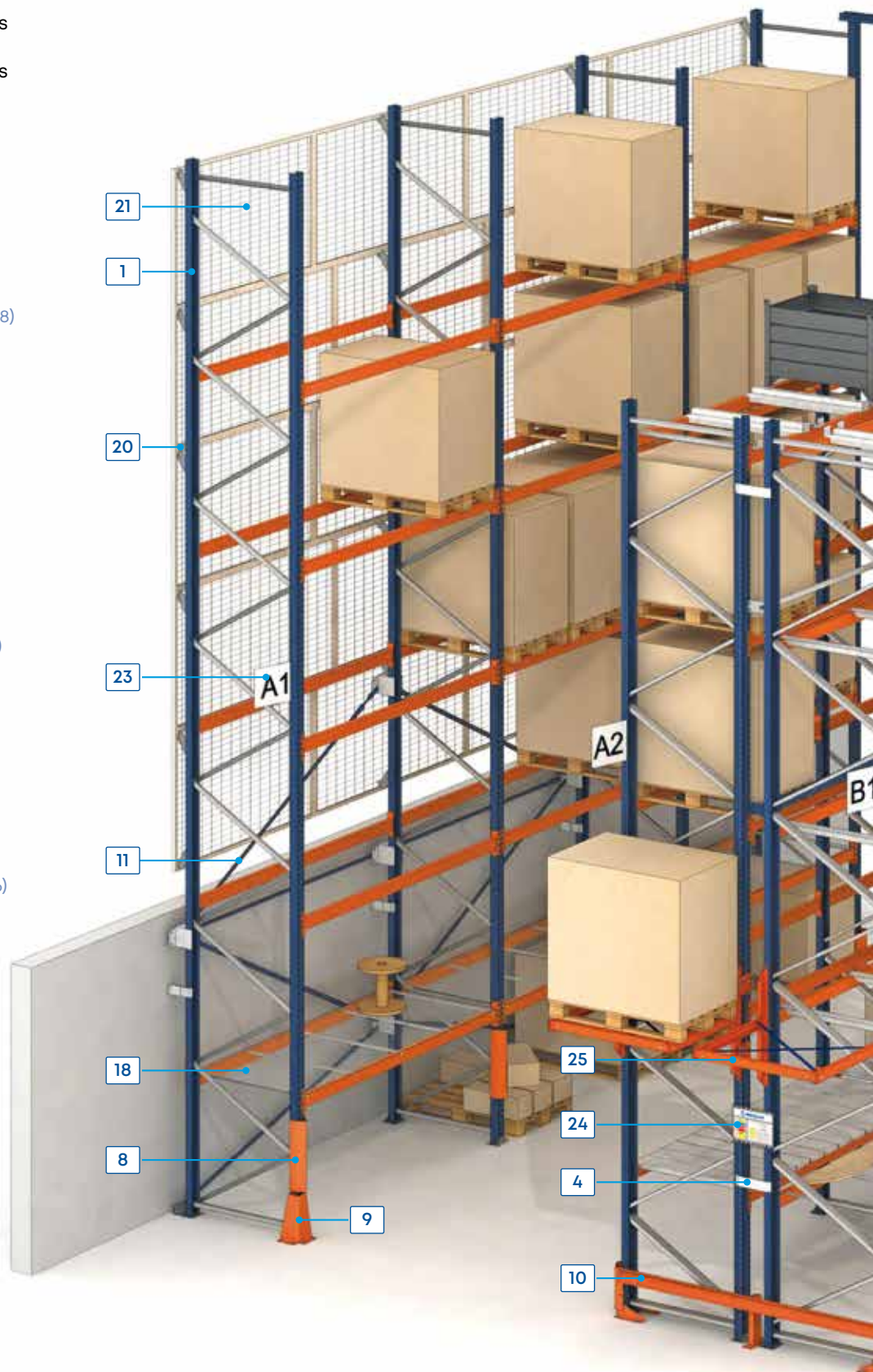



Safe load warning sign

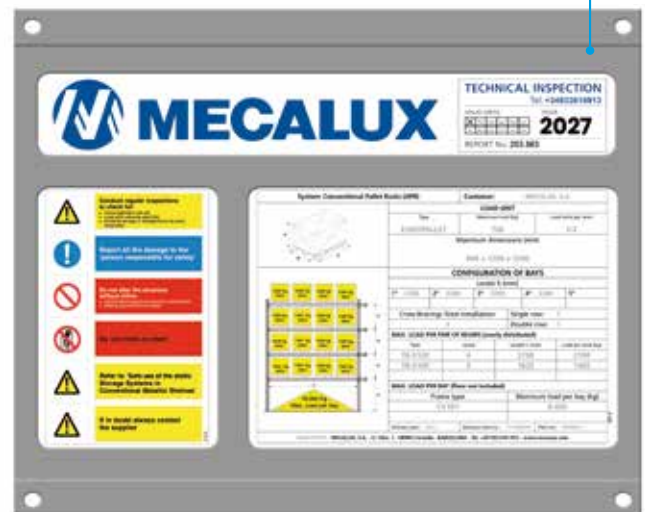

Basic components

Frames

Frames are made up of two uprights with the corresponding horizontal and diagonal bracings, footplates and accessories. Uprights are slotted every 50 mm for fitting beams to the frame.

The depth of the frame is determined by the pallet dimensions. For a Euro pallet with a depth of 1,200 mm, the frame is usually 1,100 mm deep.

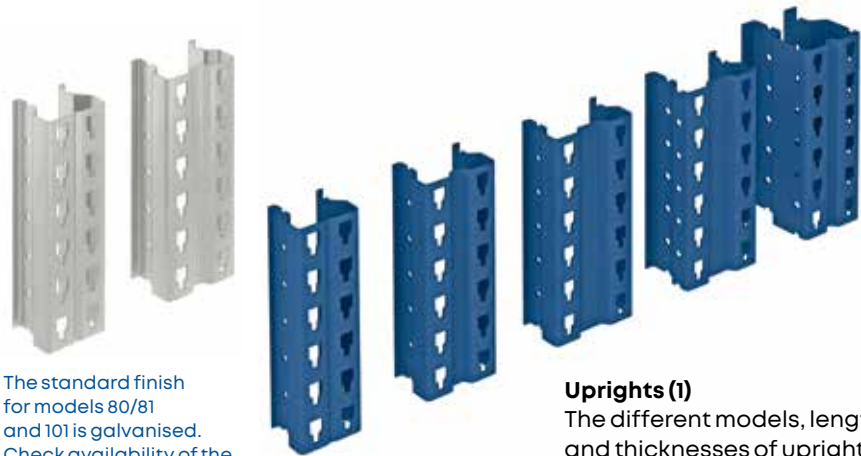
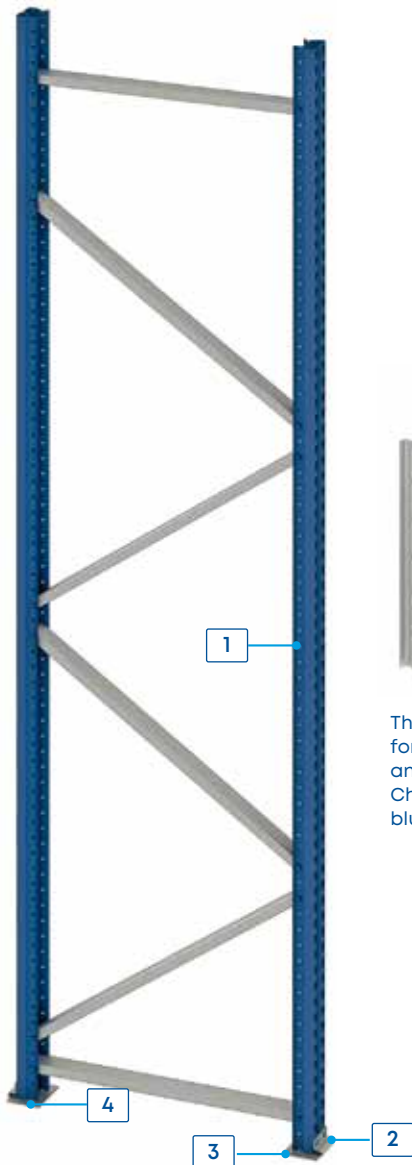

The standard finish for models 80/81 and 101 is galvanized. Check availability of the blue-painted version.

Uprights (1)

The different models, lengths and thicknesses of uprights are designed to accommodate a wide range of load requirements.

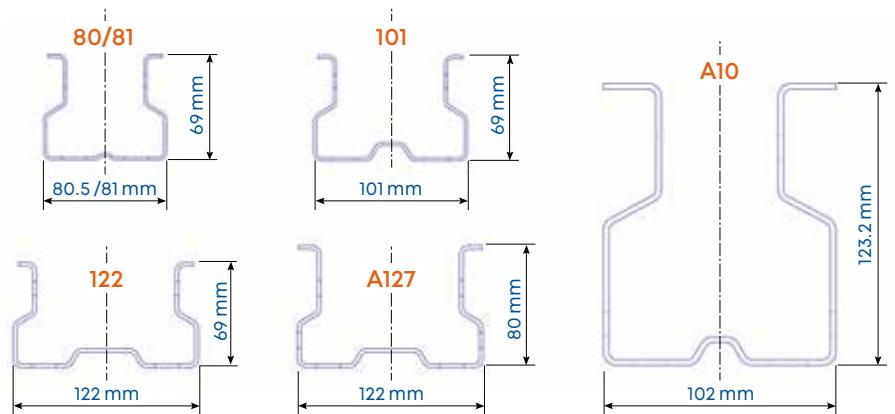



Frame footplates (2)

Frames are erected on the floor using footplates, which are fitted to the bottom of the uprights. A wide range of different frame footplates can be used, depending on the load to be supported and the upright model. They are fixed to the floor using one or two anchor bolts.

Levelling shims (3)

Shims level out racking structures installed on uneven flooring. These plates are available in various thicknesses and are specific to each upright type, ensuring more precise levelling.

Anchor bolts (4)

Racks are secured to the floor slab using anchor bolts. The type of anchor bolt varies depending on the forces the racking must withstand and the characteristics of the slab.

Footplate and shim measurements

Upright	Width	Depth	cm ²
80/81	135 mm	119 mm	1,606
101	155 mm	119 mm	1,844
122	175 mm	119 mm	2,082
127	175 mm	119 mm	2,082
A10	as per the load		



Clearances

The height between levels is calculated by adding three variables: the pallet height (including the load), the beam height and the clearance (Y). These values are rounded up to a multiple of 50 mm.

Bay tolerances and clearances:

Y: height between the pallet and the underside of the beam for levels other than floor level

X: minimum clearance between pallets or loads

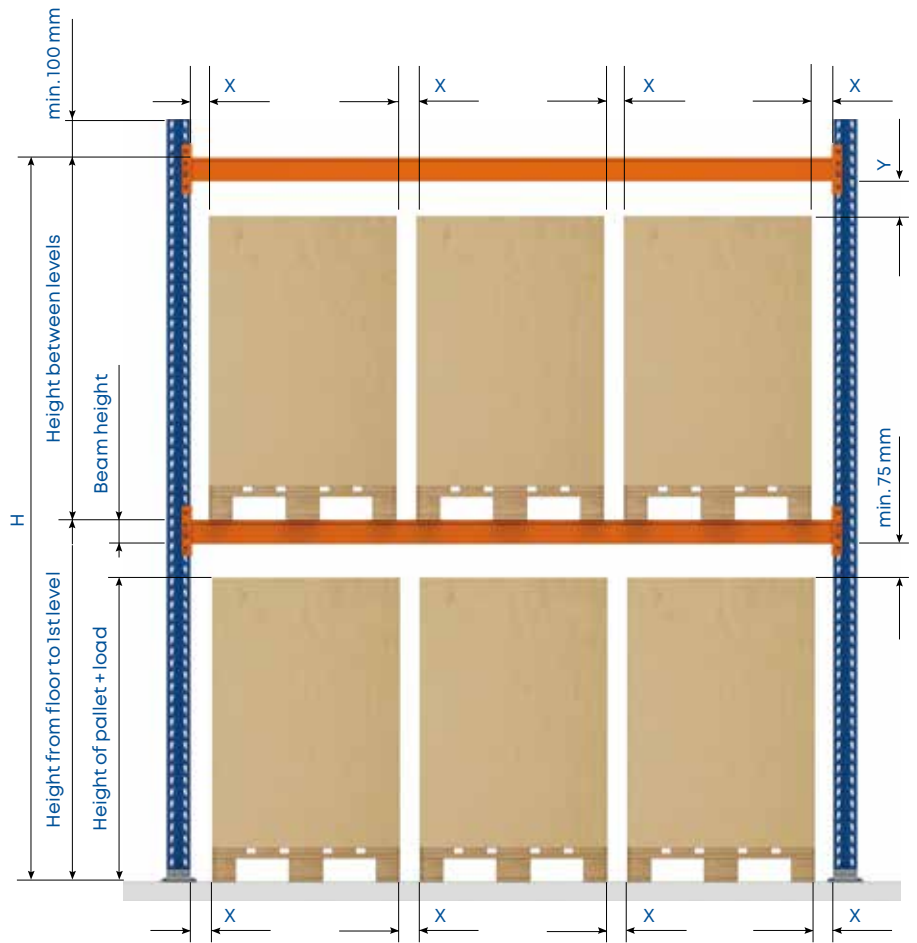

Range between levels (mm):	Class 400		Class 300A		Class 300B	
	X	Y	X	Y	X	Y
0 ≤ H ≤ 3,000	75	75	75	75	75	75
3,000 < H ≤ 6,000	75	100	75	75	75	100
6,000 < H ≤ 9,000	75	125	75	75	75	125
9,000 < H ≤ 12,000	100	150	75	75	100	150
12,000 < H ≤ 15,000	100	175	75	75	100	175
H ≥ 15,000	-	-	75	75	-	-

Clearance table for bays (or slots) according to EN 15620, in force since 2021, where:
 Class 400: Counterbalanced forklifts or reach trucks.
 Class 300 A: Man-up trilateral turret trucks (the operator moves with the load).
 Class 300 B: Man-down trilateral turret trucks (the operator remains at floor level).

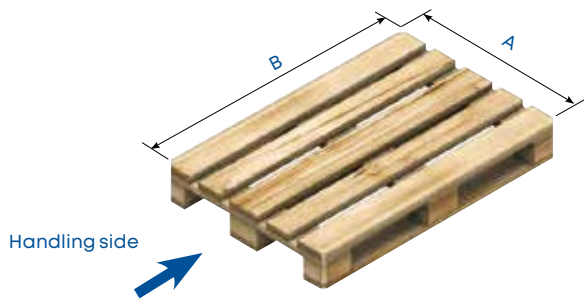

Beam measurements (up to 9,000 mm high)

Pallet		Beam	
A	B		
800	1,200	1,825	
1,000	1,200	2,225	
1,200	1,200	2,625	
800	1,200	2,700	
1,000	1,200	3,300	
1,200	1,200	3,900	

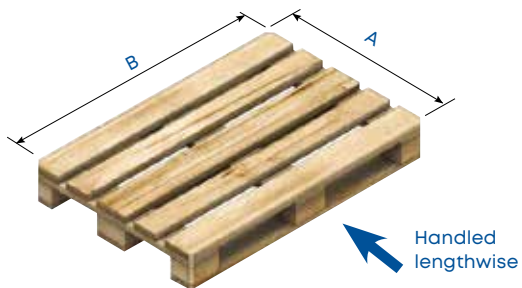

Beam measurements (up to 9,000 mm high)

Pallet		Beam	
A	B		
800	1,200	2,625	
1,000	1,200		
1,200	1,200		
800	1,200	3,900	
1,000	1,200		
1,200	1,200		

D

D

Frame depths (mm)

Pallets handled from narrow side	Pallet sizes	Pallets handled from wide size
D = 1,100	800 × 1,200	D = 800
D = 1,100	1,000 × 1,200	D = 1,000
D = 1,100	1,200 × 1,200	D = 1,200

Structural calculations

Once the rack tolerances, deformations and clearances have been determined, the structural calculation is done.

Pallet racking consists of metal structures, generally made from cold-formed sheet steel, capable of supporting heavy loads.

Pallet rack systems must be versatile enough to accommodate different types of loads. To achieve this, the connections between the main structural components must be adjustable, as well as quick and easy to assemble.

The uprights of these structures are often slotted or perforated, while the beams have built-in couplings that hook into these slots.

The EN 15512 standard (Steel static storage systems - Adjustable pallet racking systems - Principles for structural design), which is based on the Eurocodes, is the main reference for the structural design of selective pallet racking in Europe.

Moreover, engineers who design these racks must consider the EN 15620, EN 15629 and EN 15635 standards, together with EN 15512, as guidance for storage system specification, installation accuracy requirements and the safe operation of the storage system.

Standards and recommendations

Mecalux performs calculations for selective pallet racking according to the following criteria:

- **EN 15512** Steel static storage systems - Adjustable pallet racking systems - Principles for structural design.
- **EN 15620** Steel static storage systems - Tolerances, deformations and clearances.
- **EN 15629** Steel static storage systems - Specification of storage equipment.
- **EN 15635** Steel static storage systems - Application and maintenance of storage equipment.
- **EN 16681** Steel static storage systems - Adjustable pallet racking systems - Principles for seismic design.
- **FEM 10.2.16** Design and use of rack protection for adjustable pallet racking.

The EN 15512 standard stipulates the requirements to be considered when calculating selective pallet rack structures. It standardises calculation procedures, tolerances, racking assembly and system maintenance.

A structural calculation is a two-phase process:

1. Global analysis of the structure.

The stability of the entire system and its elements is verified for subsequent checking. This stage also includes modelling the actual behaviour of the connections between upright-beam and upright-floor.

2. Individual analysis of components.

This stage consists of verifying all the components that comprise the structure (uprights, frames, anchor plates, beams and connectors).

Additionally, the calculation must take into account the forces that may affect the strength and stability of the racking, such as the weight of the structure itself, the load, or actions pertaining to national regulations.

Predicting the structural behaviour of the racking is complex due to the specific characteristics of its elements. For this reason, EN 15512 also requires testing of all rack components and the materials used to manufacture them.

The aim is to determine their resilience and elastic capacities. In the case of materials, their tensile strength and ductility – the ability to bend without breaking – are also tested.



Safety device

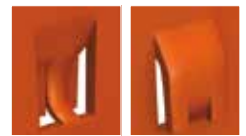

Beams

Beams are the robust horizontal racking components on which the loads are placed. They are joined to the uprights via connectors or endplates that fit into the slots on the upright. The hooks on these connectors – in the connection system designed and patented by Mecalux – are attached to the main rack structure at both ends. This feature considerably increases load capacity and prevents deformations that typically occur when the connection between the main structure and the connector or endplate is not sturdy enough.

This reduces the risk of the beam falling, which could occur if, due to fatigue, the connector began to loosen. Each beam has two built-in safety devices to prevent accidental falling.

Mecalux manufactures a wide range of beams for different storage needs in terms of size, as well as load type and capacity. The measurements of the load levels are determined by the number and dimensions of the pallets stored, as indicated in the rack clearance table.

Tubular beams

These are made from a single rolled tube welded to two connectors or endplates.

Model TB	Height (A)	Width (B)
TB 80	80	50
TB 100	100	50
TB 120	120	50
TB 130	130	50

Dimensions in mm

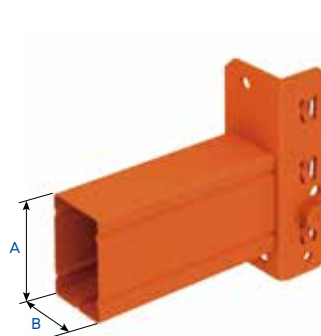

TB beam (80)

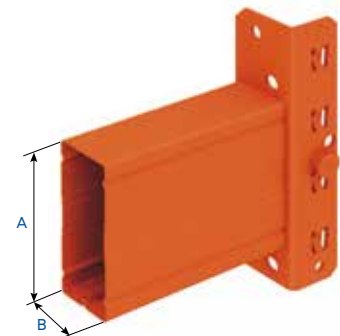

TB beam (100, 120, 130)

2C-S beams

There are five standardised models, grouped into two families distinguished by the dimensions of the connectors or endplates.

Model 2C-S	Height (A)	Width (B)
1115	110	50
1315	130	50
1515	150	50
1615	160	50
1718	170	50

Dimensions in mm

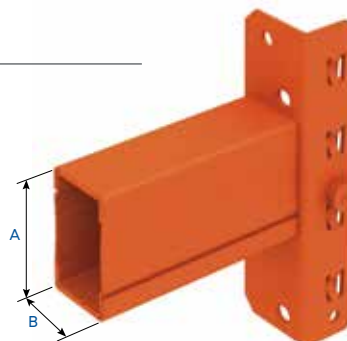

2C-S beam (1115)
Made from two C-shaped profiles fitted into each other and welded to an endplate.

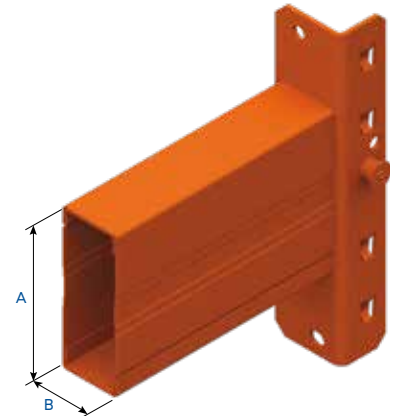

2C-S beam (1315, 1515, 1615, 1718)
These beams are used for heavy loads and longer products due to their superior strength.



Mixed beams for pallets and picking

These beams consist of a single shaped tube welded to two connectors or endplates. They are used to configure mixed storage of pallets and picking on the same levels, or for pallets of different sizes and types.

Shelving panels are required for this type of mixed storage. When these shelves are made of chipboard, slotted beams are installed to allow reinforcement deck supports to be inserted into the profile slots.

Model TB	Height (A)	Width (B)
TBE-S 32	82	70
TBE-S 45	114	70
TBER-S 32	82	70
TBER-S 45	114	70

Dimensions in mm

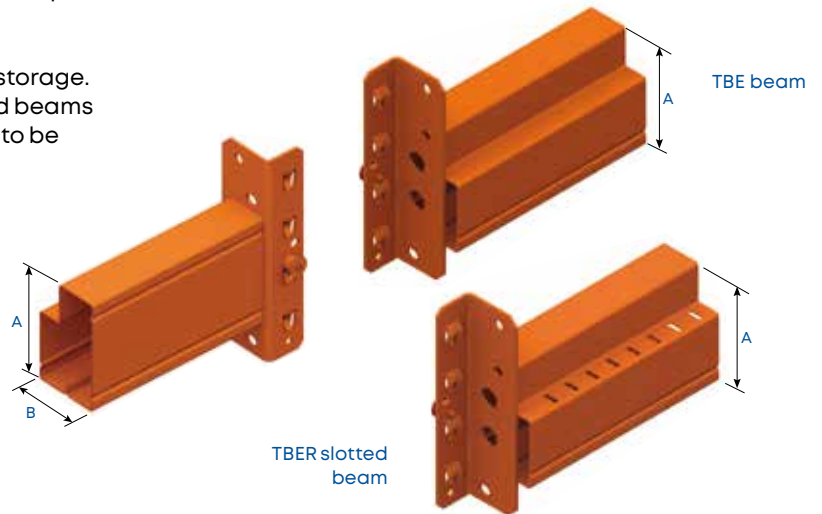

Picking beams

Shelves can be fitted into these beams for storing loose goods or performing picking operations.

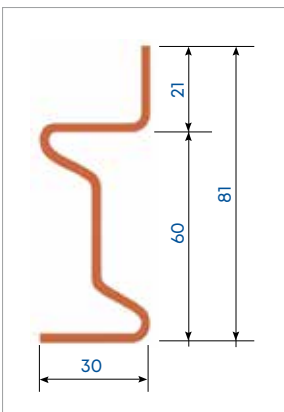

Dimensions in mm



ZS-60P beam

This beam is made from a Z-shaped profile welded to a connector with four hooks at each end. The profile has a flange at the top that acts as a stop and provides support for the shelf.

This beam is used to create picking levels in selective pallet racking systems.



Locking mechanism and row spacer

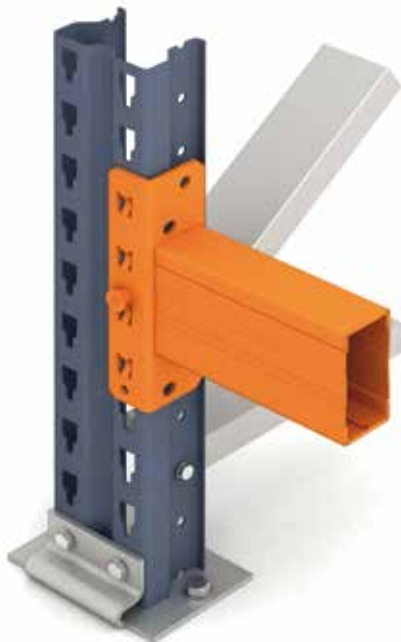

Safety locking mechanism

The endplate that joins the beam and the upright includes a built-in safety locking mechanism, designed to make the structure even safer.

As the safety mechanism is integrated into the endplate, it is always engaged. Once installed, the beam cannot be removed without disassembling it. This feature prevents the device from being moved either accidentally or deliberately, ensuring the strength and stability of the racking.

This innovative system is exclusive to Mecalux.

Row spacer

Steel piece designed to attach to the uprights, secured by bolts at its ends.

Row spacers connect double-access racks, providing them with greater lateral stability.



Accessories



Shelves

Various shelf types are available to suit any storage requirement. These are the most common:



L-2C galvanised shelves

Metal shelves that, depending on the storage need, can be placed on tubular or 2C beams. They fit directly on the beams and do not require further fixing.

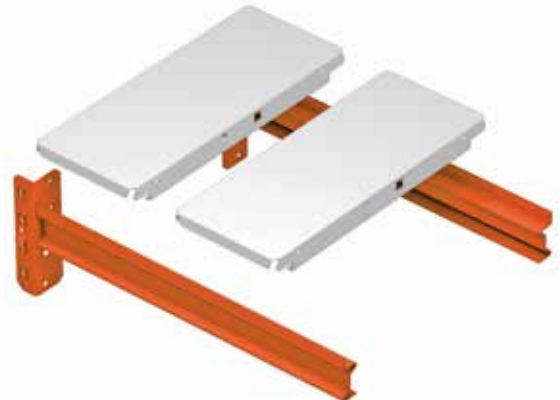

Galvanised picking shelves

Metal shelves used exclusively with ZS-60 beams. The shelf panels fit together via tabs and slots.



Grooved metal shelf



Slotted metal shelf



Perforated PKM shelf

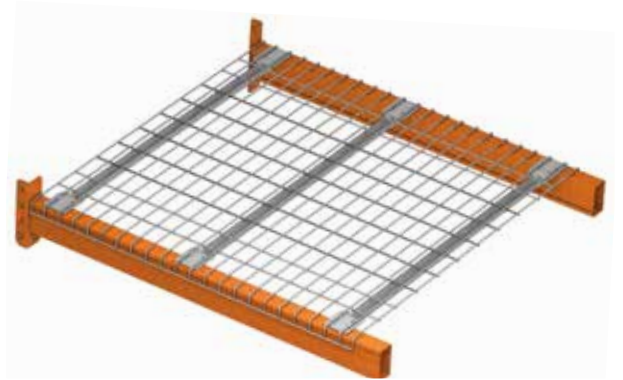

Mesh shelf

Made from rectangular electro-welded mesh that rests on deck supports, strengthening the structure. These shelving panels are placed on the beams and do not require additional fastening.



Chipboard shelves

Chipboard deck supports

Retainer

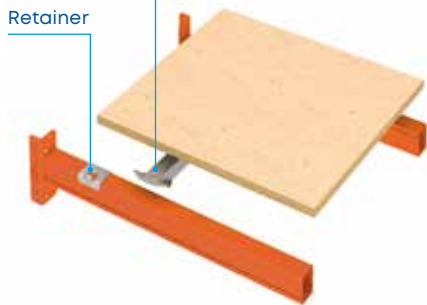

With tubular or 2C beams

Chipboard shelves can be placed on tubular or 2C beams, secured with four retainers. Chipboard deck supports can also be used for this type of setup.

Chipboard deck supports

Z TAM clamps

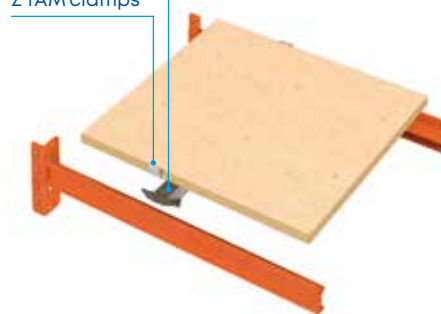

With Z beams

Chipboard shelves typically do not require any fasteners when placed on Z beams, as the panel edge sits hidden and supported on the beam profile.

Depending on the load, chipboard deck supports can be added. For lengths $\geq 1,900$ mm, a single Z TAM clamp is required per beam to ensure a correct fit.

Chipboard deck supports

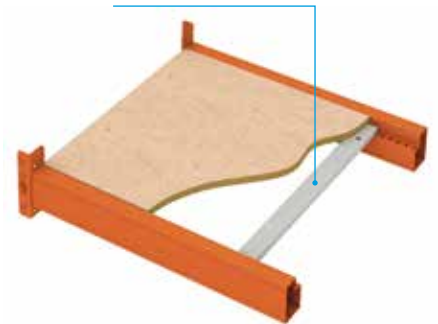

With TBER beams

Chipboard shelving panels require at least two chipboard deck supports to be placed on the slotted TBE beams, even if the panel edge is concealed and rests on the beam profile. Depending on the load, additional deck supports can be added as needed.





Double-profile side protector



Single-profile side protector



Protectors

These parts shield the racking from minor accidental impacts at floor level, preventing damage to the vertical elements.

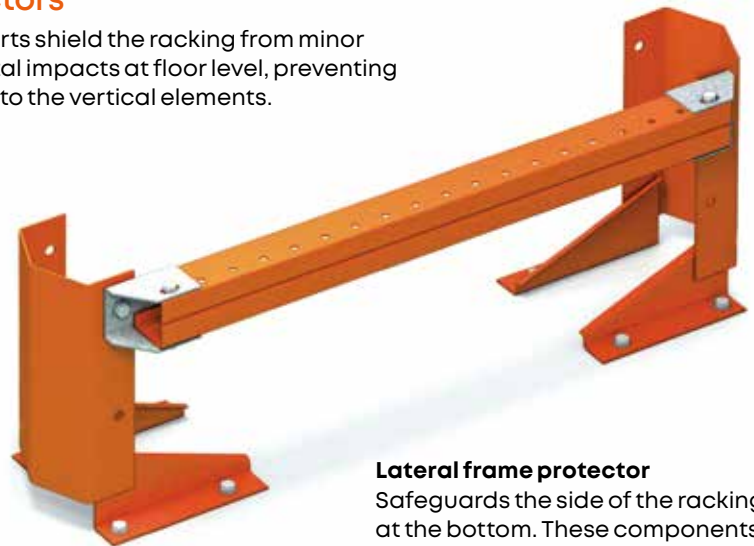

Lateral frame protector

Safeguards the side of the racking at the bottom. These components are normally installed on end frames and in aisles or passageways where impacts are most likely. There are protections for each type of upright. To safeguard the entire side of a frame, two upright protectors and one C profile are used. Two C profiles can also be fitted if requested.



Upright protector

Each upright has its own type of protector. These components are 400 mm high and come with four anchor bolts to affix them to the floor. They are used to shield uprights from blows and possible damage in systems operated by forklifts.



Corner protector

Protects the external uprights when upright protectors cannot be fitted. It consists of a 400 mm high folded metal plate with four holes at the base for securing to the floor.



Upright reinforcer

When it is necessary to protect the uprights at a certain height and upright protectors cannot be installed, an upright reinforcement is used. It is fixed directly to the upright rather than to the floor. Upright reinforcers are made from wedge-shaped folded sheets with lateral holes for attachment to the uprights. These reinforcers are available in different heights for each type of upright.



Close-up of a galvanised pallet support bar

Pallet and container support bars

Depending on how the pallet or container is placed in the racking, extra support may be needed in addition to the beams, such as pallet or container support bars.

Galvanised pallet support bars

Fitted perpendicular to the beams, these provide support to pallets when they are placed on the rack with their lower deckboards parallel to the beams or when the pallet is of poor quality. One to three support bars are required per pallet, depending on the pallet's quality and weight.



Raised pallet support bars

Necessary when storing pallets without bottom deckboards.



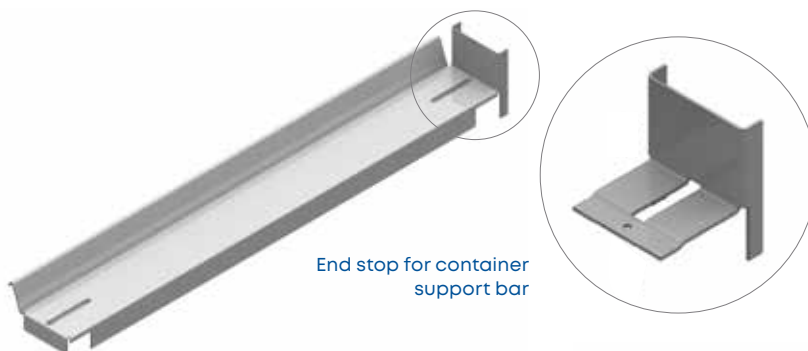

End stop for container support bar

Container support bar

This component is fitted when racks store containers with legs instead of skids. Two support bars are used per container, one on the right and one on the left.

Container support bars can be fitted with end stops, which are bolted to the back of each support bar.

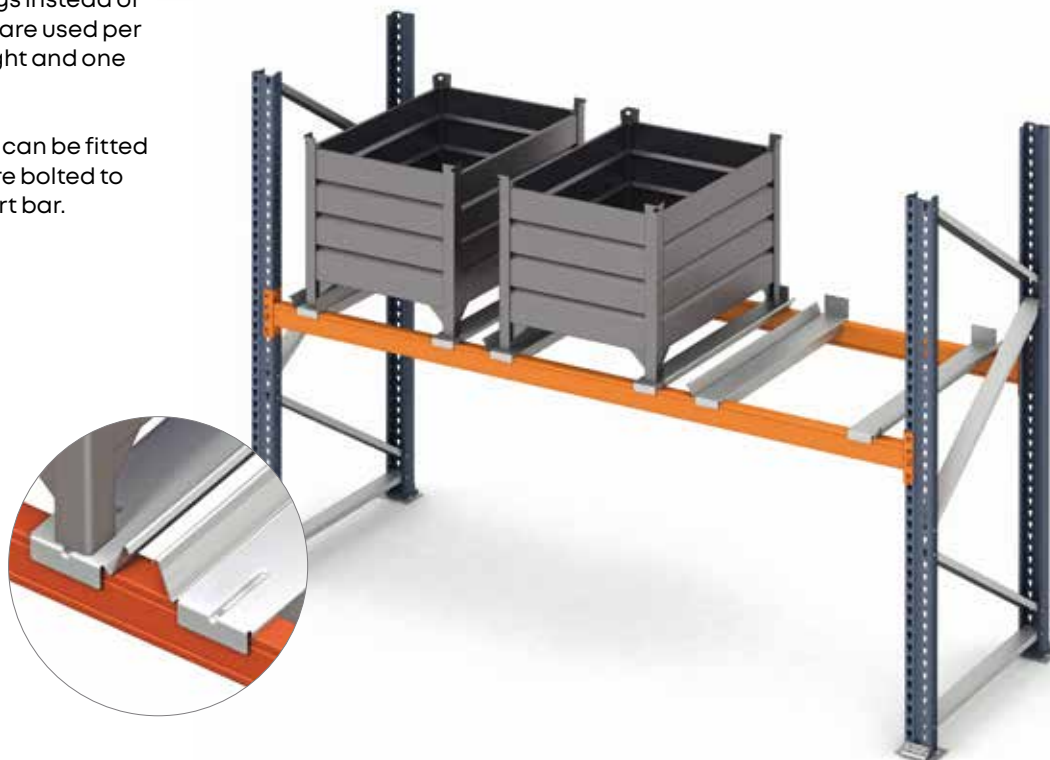



Cylinder and drum supports



2L cylinder support

This set is made of two L-shaped profiles joined by two front profiles. Together, they form a frame that ensures the secure placement of the cylinder. They are fitted onto the racking beams.



Roller drum support

Made of two rollers on which the drums rotate to enable liquid dispensing. A bottom tray catches any liquid to prevent spills.



Front drum support

This 50 mm metal part couples to the beams, adapting the load levels to store drums.

A drum support is placed horizontally on each beam. Its V-shape provides the support needed to hold drums and reels in place.



Reel supports

Reel supports store cylinder-shaped items on a metal axle (cable reels, paper reels, etc.).

Two systems are available: front storage and side storage, depending on the characteristics of the goods, their sizes and use.

As complementary accessories, support axles and collars are available to prevent lateral movement.



Front reel support

The front reel support is fitted to the front upright of the frame, where it is slotted into the upright.



Side reel support

Bolted to the side of the frame, the side reel support positions the reel in the centre of the frame.



Support axle and collars

The axle is a cylindrical part with a 60 mm diameter and is available in various thicknesses. It rests directly on the supports and functions as shaft on which the reels rotate.

Conical-shaped adjustable collars can be used as end stops to prevent reels from sliding along the axle.





Safety features

These supplementary components enhance storage system safety and prevent goods or pallets from falling.

The following add-ons are available:

- Positioning profiles
- Safety profiles
- Fall protection mesh



Positioning profile

Mounted at the back of the racking to keep the pallet (not the load) in constant contact with the profile.

This profile has to withstand the forces produced during pallet positioning, so the rack must be designed accordingly.

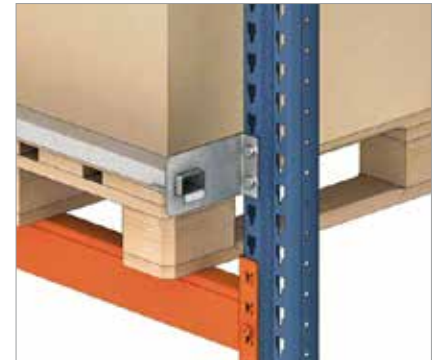

Safety profile

This profile acts as a warning system to prevent a pallet from falling. It is not designed to withstand pallet positioning forces or serve as a braking system for deliberate manoeuvres.

In this system, it is the load (not the pallet) that butts up against the safety profile.

This accessory serves as a safety mechanism to prevent potential falls or collisions with unit loads resulting from improper manoeuvring of the handling equipment.

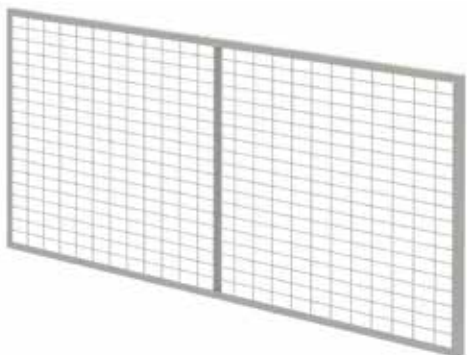

Fall protection mesh

These wire mesh panels can be installed when loads are not shrink-wrapped or the safety profile alone may not prevent goods from falling. This optional safety measure is fitted at the rear of racks when there is a risk of load collapse. It can cover all or part of the rack height.

When a single rack borders on a work or traffic area, mesh protection is required to prevent accidental falling of materials, entrapment or other hazards.



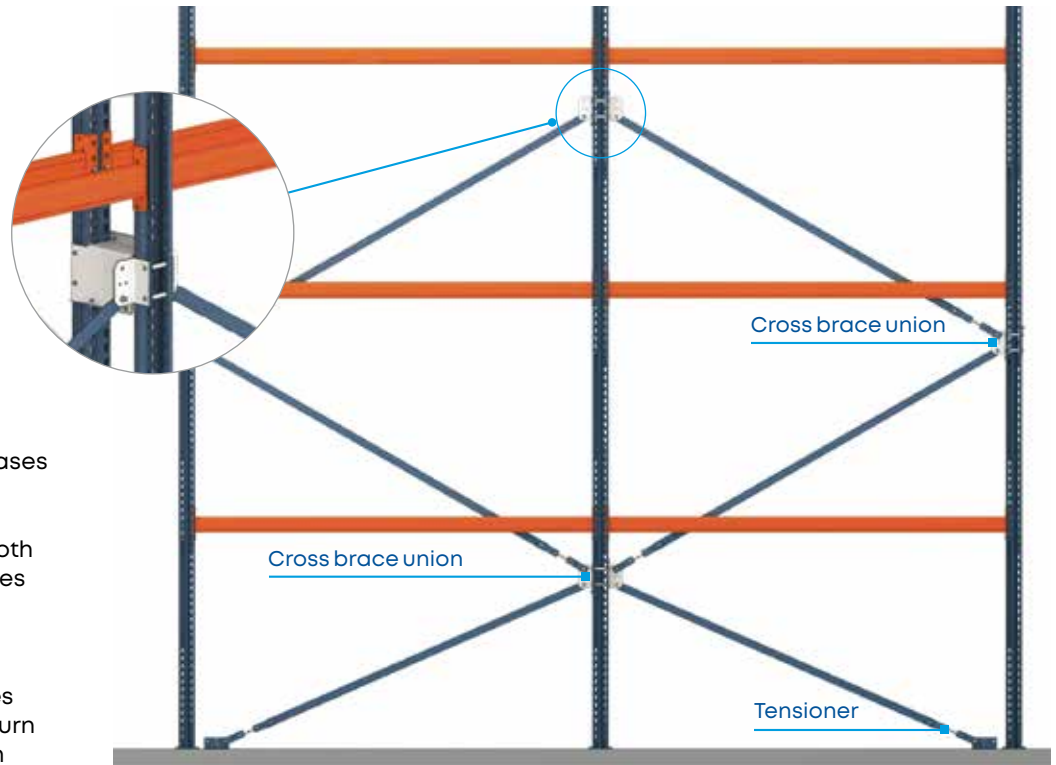

Cross bracing

This system of profiles increases the longitudinal stability of a storage system. When the load and height require it, both vertical and horizontal braces are installed.

Vertical cross bracing

These braces are flat profiles fitted to supports, which in turn are fixed to the frames. Each profile has a tensioner that provides it with the necessary rigidity.

Horizontal cross bracing

These C-shaped profiles are bolted to the inner upright of the racks, at the same height as the beams.

Horizontal bracing is installed in the same bays as the vertical bracing and on the same number of levels.

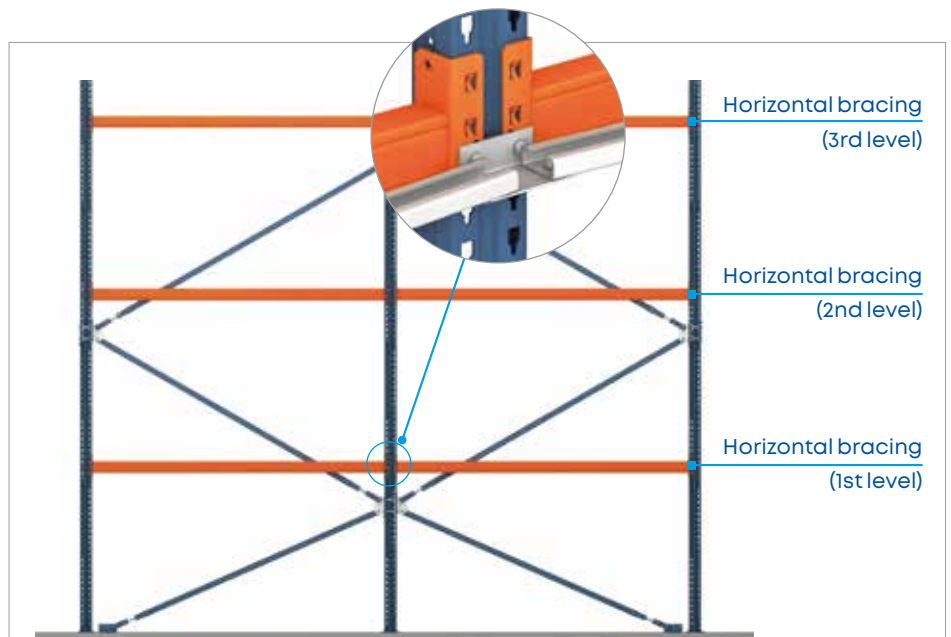

Frame splice

For storage systems requiring very tall frames, a set consisting of two symmetrical frame splice pieces is needed. These are bolted to the inner face of the uprights being joined.



Rack identification accessories



Aisle sign

Rectangular metal plate installed on the ends of racking units to identify them via letter or number. They have three mounting positions depending on the desired viewing angle.



Upright card holder

Designed to house identification cards that may be changed over time.



Flat card holder

Allows the attachment of fixed identification cards.

Racking inspection label

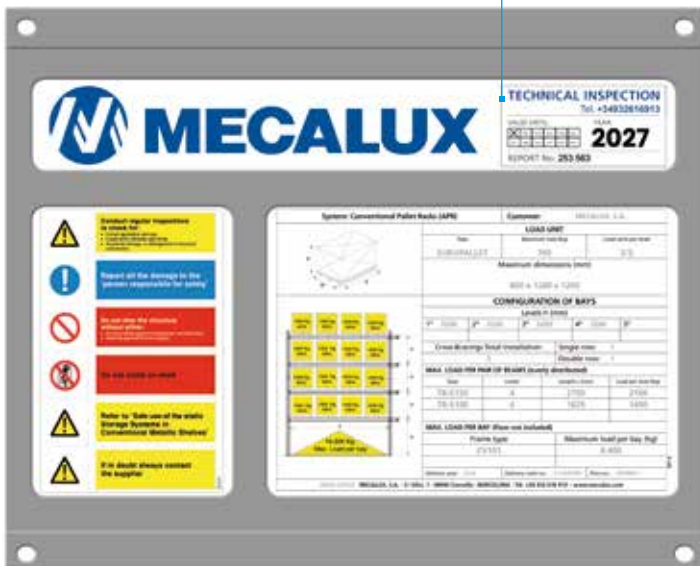

Safe load warning sign

Plates used to list the technical specifications of the storage systems. They are visibly displayed on the ends of racking units.

Racking inspection label

To keep the storage system in optimal condition and ensure long-term safety, regulations require an annual inspection. Ideally, this should be conducted by the rack manufacturer. Mecalux's Racking Inspection Service issues a report certifying the condition of the storage system and a sticker to affix to the safe load warning notice, indicating the deadline for the next inspection.



High-bay pallet racking with narrow aisles

This storage system features very tall racks separated by narrow aisles. Its main advantages are excellent use of space and direct access to any stored pallet.

Turret trucks or stacker cranes handle the unit loads.

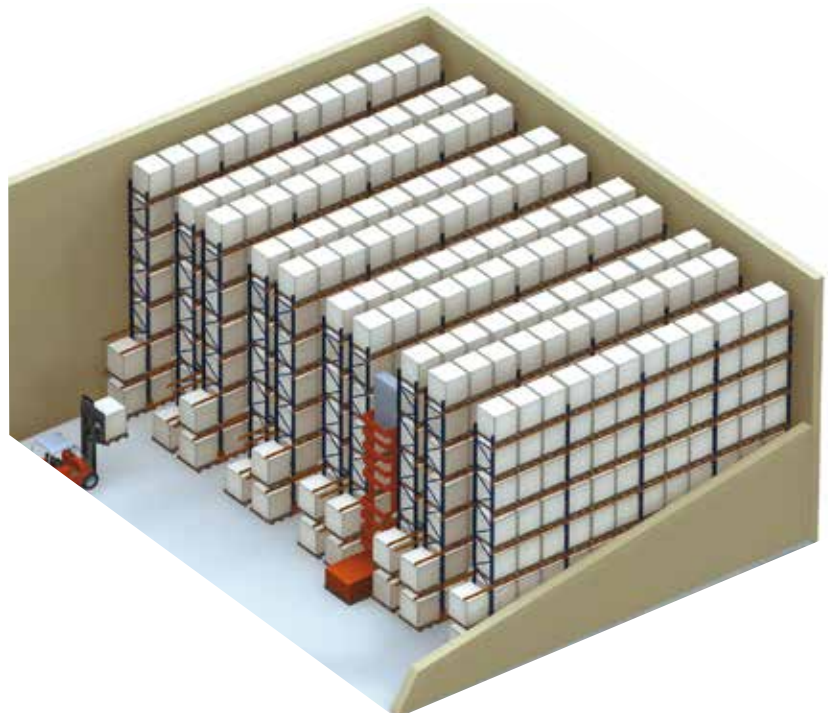

Turret trucks

Turret trucks are designed to work in narrow aisles, generally with high-bay pallet racking. These machines need to be guided along the storage aisles.

Outside the storage aisles, the trucks manoeuvre slowly, so their work is mainly focused within the aisles. They are usually supported by more conventional handling devices, which deposit and pick up pallets at the ends of the racking units.

Turret trucks can be classified into two different systems:



Man-up system (Class 300A)

The operator sits inside the onboard cabin, which moves up and down with the goods. This enables greater manoeuvrability and allows the operator to pick directly from the pallets.

It is also known as a 'combi' system, since both pallet storage and picking operations can be combined.

Man-down system (Class 300B)

This system features a truck in which the operator's cabin remains stationary while the load moves up and down.

A viewing camera and a height selector facilitate manoeuvring.



Trilateral fork

Fork types

Goods can be handled with two types of forks: trilateral and bilateral.

Trilateral fork

Trilateral forks enable pallets to be picked up from and deposited on the floor in three positions: from the front and from either side of the truck via a rotating head.

Bilateral fork

Bilateral forks must only pick up and deposit pallets at a raised position; they cannot pick pallets directly from the floor. Storage systems using this fork type require taller racking and narrower aisles.

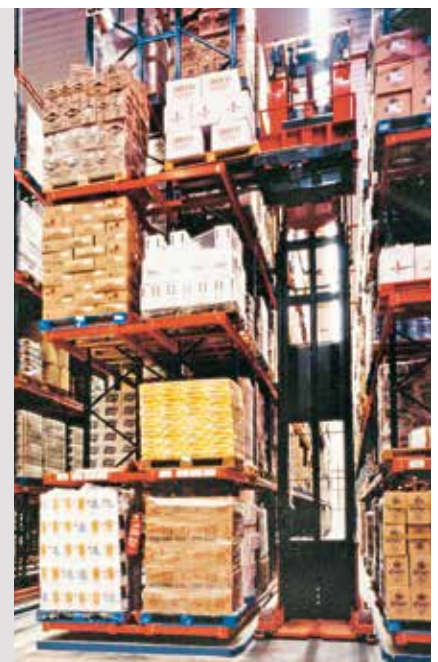

Bilateral fork



Guidance systems for turret trucks

Turret trucks must be guided along the storage aisles.

These vehicles can be wire-guided, where a wire is embedded in the floor and generates a magnetic field to direct the truck's movement. Alternatively, the system is mechanically guided, using guide rails fitted to both sides of the aisle and anchored to the floor.

Each truck model requires a specific type of guide rail and a defined aisle width. The aisle width must take into account both the distance between the guide rails and the clearance between the pallets.

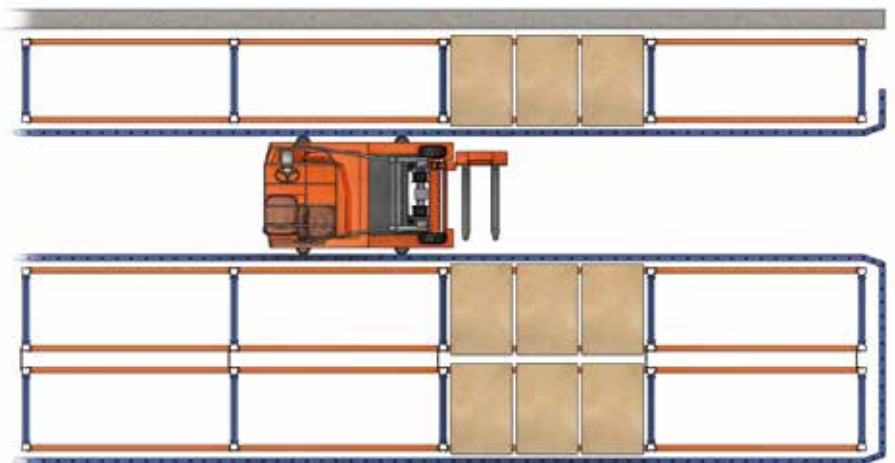

Mechanical guidance general layout

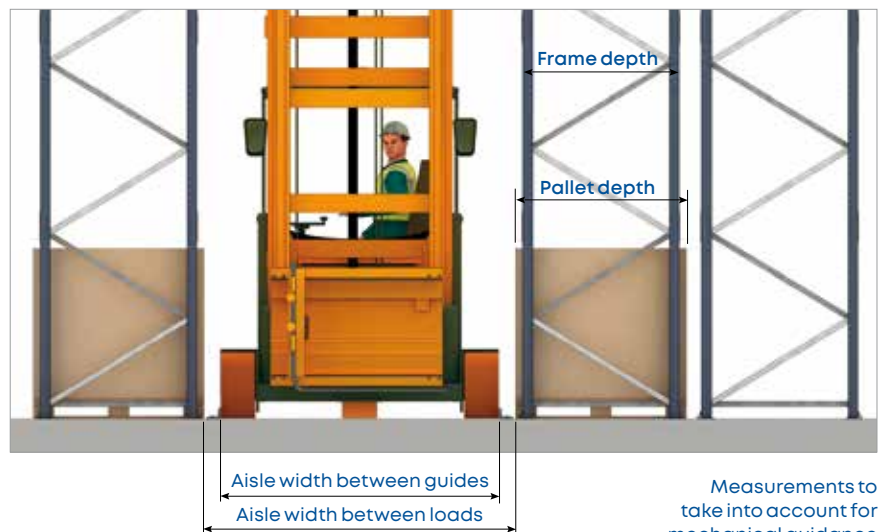

Measurements to take into account for mechanical guidance

Mechanical guidance

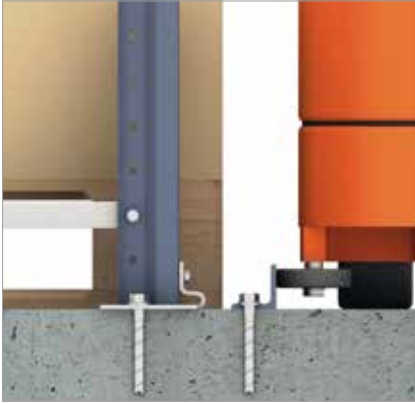

Guidance using LPN 50 profiles
Pallets sit directly on the floor.



Guidance using UPN 100 profiles
Pallets are set on profiles attached to the floor or on the beams.

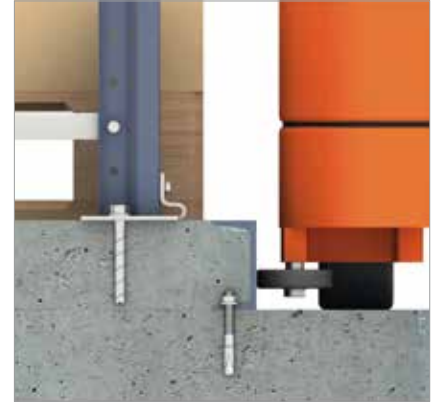

Guidance using UPN 100 profiles with a concrete platform
The space between the guide rails of two aisles is filled in with concrete, and the racks are erected on top of the concrete platform.



At the entrance of aisles with mechanical guidance, entry profiles with reinforced openings are installed to help centre the vehicles.

Wire guidance

A wire embedded in the floor produces a magnetic field that guides the vehicle.



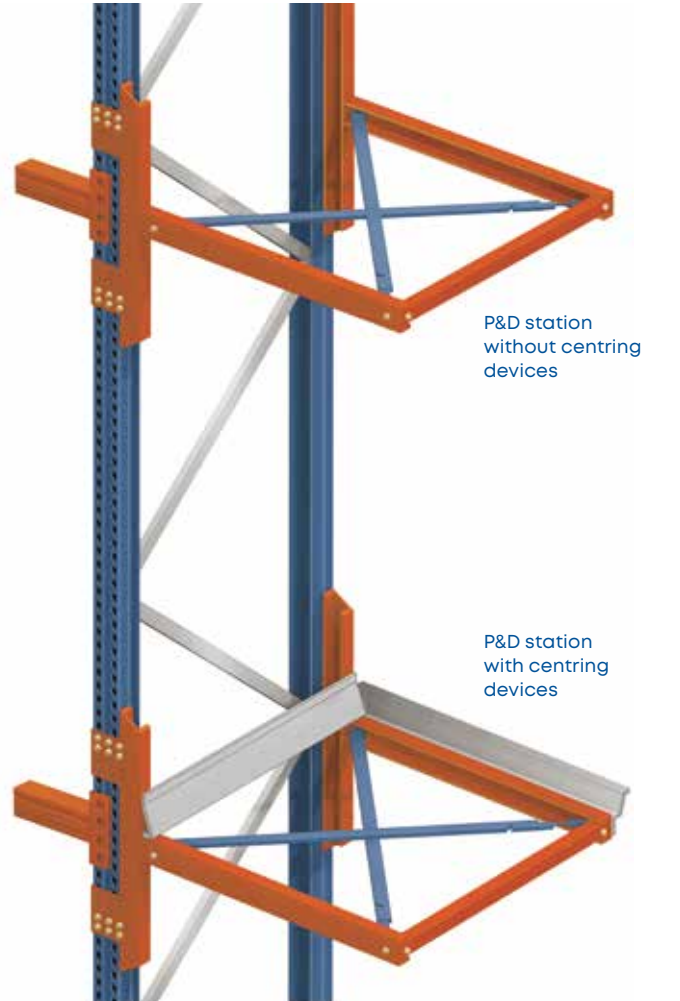

P&D stations

P&D stations are installed at the ends of the racks to deposit pallets temporarily in warehouses with flows requiring this setup.

Turret trucks, designed primarily to work inside aisles, pick pallets and place them on the P&D stations.

More conventional forklifts then handle the pallets from these points. Various types of P&D stations are available to fulfil different storage needs, such as the number of levels, dimensions or load capacity. P&D stations can also be fitted with pallet centring devices. These

enable more precise positioning, making it easier to place pallets in locations with low clearance margins.

When mechanical guidance is used, pallet support profiles must also be fitted at the rack ends.

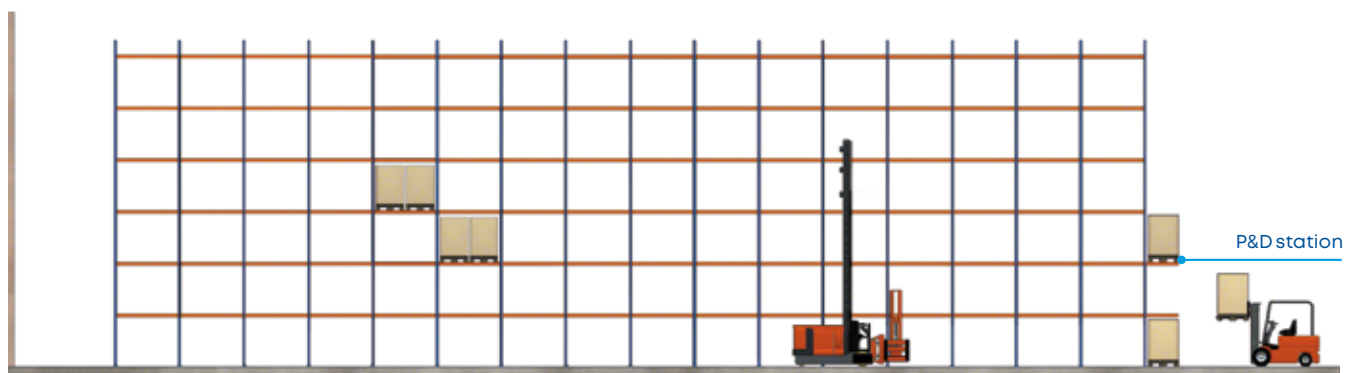



Conveyor systems

In warehouses with high-bay storage systems, pallets can be transported from the docking area to the racking automatically. Roller or chain conveyors are typically installed for this purpose. Some facilities employ transfer cars, which move pallets to and from the racking entry and exit points.



Automatic trilateral stacker cranes

Selective pallet rack storage systems up to 15 m high can be easily automated using this solution.

This stacker crane moves pallets to the end of the aisle, depositing loads on P&D stations or a conveyor system. Thanks to its rotating head, it can pick up and place pallets in three positions: one frontal and two lateral.

Operations are fully automated. All stacker crane movements are executed according to storage or retrieval commands issued by the control system, which optimises travel.



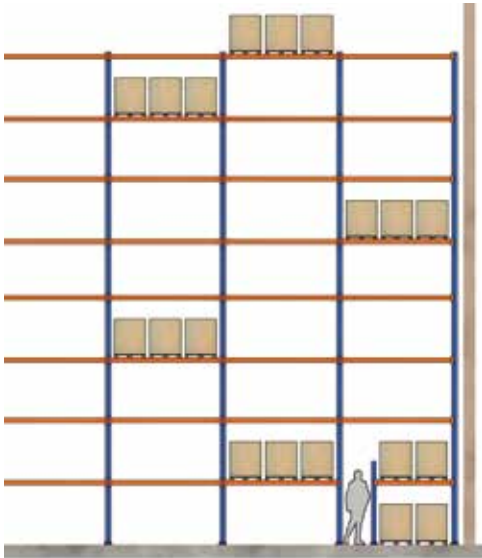

Side view of a storage system with a passageway

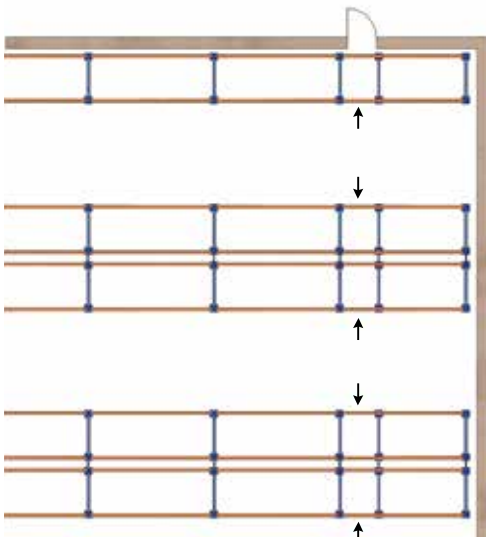

Top view of a storage system with a passageway



Safety accessories

Safety passageways

For safety reasons, a storage system may require ground-level passageways running through the racks as emergency exits.

Top portal tie

High-bay racks are often connected at the top by portal ties to increase overall stability. These portal ties must be positioned above the maximum lifting height of the machines, including the mast and cabin.

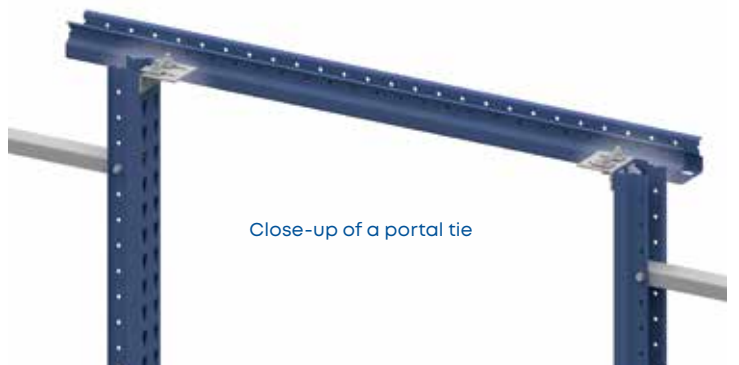

Close-up of a portal tie



Fire safety systems

High-bay racks are usually equipped with a built-in fire protection system.

When installing pipes and sprinklers, the necessary clearances between the racking units and levels must be allowed for.

Pipes and sprinklers are positioned in the spaces between the beams.





Easy WMS warehouse management system

The brain of the facility

Easy WMS is a powerful, versatile, scalable and flexible software solution that oversees manually operated warehouses (paper- or RF-scanner-based), mixed facilities and large automated centres with the same efficiency.

It optimises physical product flows and document management, from warehouse inputs through to final dispatch, ensuring full end-to-end traceability.

Benefits

- > Real-time stock control
- > Lower logistics costs
- > Increased storage capacity
- > Reduced handling tasks
- > Error elimination
- > Accurate, high-speed picking
- > Adaptation to new e-commerce needs
- > Management of omnichannel operations
- > Fast ROI (in 12-18 months)

Mecalux works with leading suppliers that attest to the quality, reliability and technical capabilities of the Easy WMS platform:

ORACLE | Partner

SAP® Certified
Integration with SAP Applications

Microsoft Partner

ZEBRA
TECHNOLOGIES
SEE MORE. DO MORE.

Interconnected solutions for the supply chain



Multi-Carrier Shipping Software

Automates product packaging, labelling and shipping. It coordinates direct communication between the warehouse and the various transport companies.



Labor Management System (LMS)

Maximises operational productivity. It objectively measures operator throughput, identifying improvement opportunities for companies.



Slotting for WMS

Streamlines location management in the warehouse. It determines the optimal slotting for each SKU based on a set of predetermined rules and criteria (historic, current and future demand).



WMS for 3PL

Manages billing between a 3PL provider and its clients. A dedicated access platform provides information on inventory status and how to place orders or request customised shipments.



WMS for Automation & Robotics

Connects Easy WMS to the main automated storage and retrieval systems (AS/RSs) and robotic intralogistics solutions.



Yard Management System (YMS)

Supervises vehicle movements in the yard of a warehouse or distribution centre. YMS optimises loading dock operations to improve vehicle flow and avoid bottlenecks in inbound and outbound operations.



WMS for Manufacturing

Provides traceability in production processes and guarantees the continuous supply of raw materials to production lines.



Store Fulfilment

Synchronises inventory and workflows to ensure optimal stock management between the central warehouse and the network of brick-and-mortar shops.



Marketplace Integration

Coordinates warehouse inventory with the online catalogue in real time. Easy WMS automatically connects to the main digital sales platforms and marketplaces such as Amazon, eBay and PrestaShop.



Value-Added Services (VAS)

Facilitates product personalisation to drive customer satisfaction. The software sends operators step-by-step instructions on how to customise items and eliminate errors.

Easy WMS in the cloud

- **Lower initial investment** since in-house servers are not needed.
- Faster, simpler **implementation**.
- Easier, more affordable **technical support and maintenance**. Total security with Microsoft Azure.
- Software **version up-to-date** at all times.
- **Maximum availability** to guarantee business continuity.



info@mecalux.co.uk - mecalux.co.uk

MECALUX UK LTD.

BIRMINGHAM

Tel. 0121 3336 602

Unit 8, Junction 6 Industrial Park
Electric Avenue, Birmingham B6 7JJ
West Midlands - (United Kingdom)

MECALUX, SA

HEAD OFFICE

Tel. + 34 932 616 913

Silici, 1
08940 Cornellà de Llobregat
Barcelona (SPAIN)

Mecalux has commercial offices in 26 countries

Offices in: Argentina · Belgium · Brazil · Canada · Chile · Colombia · Croatia · Czechia · Estonia · France · Germany · Italy · Latvia · Lithuania · Mexico · Netherlands · Poland · Portugal · Romania · Slovakia · Slovenia · Spain · Turkey · UK · Uruguay · US

